 **BOSS**

RSD-10

**DIGITAL SAMPLER /
DELAY**

INSTRUCTIONS

- Please read the instructions carefully

Radio and television interference

“Warning — This equipment has been verified to comply with the limits for a Class B computing device, pursuant to Subpart J, of Part 15, of FCC rules. Operation with non-certified or nonverified equipment is likely to result in interference to radio and TV reception.”

The equipment described in this manual generates and uses radio-frequency energy. If it is not installed and used properly, that is, in strict accordance with our instructions, it may cause interference with radio and television reception.

This equipment has been tested and found to comply with the limits for a Class B computing device in accordance with the specifications in Subpart J, of Part 15, of FCC Rules. These rules are designed to provide reasonable protection against such an interference in a residential installation.

However, there is no guarantee that the interference will not occur in a particular installation. If this equipment does cause interference to radio or television reception, which can be determined by turning the equipment on and off, the user is encouraged to try to correct the interference by the following measure:

- Disconnect other devices and their input/output cables one at a time. If the interference stops, it is caused by either the other device or its I/O cable.

These devices usually require Roland designated shielded I/O cables. For Roland devices, you can obtain the proper shielded cable from your dealer. For non Roland devices, contact the manufacturer or dealer for assistance.

If your equipment does cause interference to radio or television reception, you can try to correct the interference by using one or more of the following measures:

- Turn the TV or radio antenna until the interference stops.
- Move the equipment to one side or the other of the TV or radio.
- Move the equipment farther away from the TV or radio.
- Plug the equipment into an outlet that is on a different circuit than the TV or radio. (That is, make certain the equipment and the radio or television set are on circuits controlled by different circuit breakers or fuses.)
- Consider installing a rooftop television antenna with coaxial cable lead-in between the antenna and TV.

If necessary, you should consult your dealer or an experienced radio/television technician for additional suggestions. You may find helpful the following booklet prepared by the Federal Communications Commission:

“How to Identify and Resolve Radio-TV Interference Problems”

This booklet is available from the U.S. Government Printing Office, Washington, D.C., 20402, Stock No. 004-000-00345-4.

Bescheinigung des Herstellers /Importeurs

Hiermit wird bescheinigt, daß der/die/das

DIGITAL SAMPLER/DELAY RSD-10

(Gerat, Typ, Bezeichnung)

in Übereinstimmung mit den Bestimmungen der

Amtsbl. Vfg 1046 / 1984

(Amtsblattverfügung)

funk-entstört ist.

Der Deutschen Bundespost wurde das Inverkehrbringen dieses Gerätes angezeigt und die Berechtigung zur Überprüfung der Serie auf Einhaltung der Bestimmungen eingeräumt.

Roland Corporation Osaka / Japan

FEATURES

The BOSS RSD-10 features two functions; the **SAMPLER** that allows pitch and dynamics control and the **DELAY** that allows as long as 2 second delay time. Adopting the circuit for pitch controlling by audio signal, the RSD-10 can be used with any type of synthesizer, varying the pitch of the sample sound more than 2 octaves. Also, the dynamics, pitch bender, vibrato, portamento, attack time, and decay time can be controlled if the keyboard used features such functions. (e.g. the JX-8P features all these functions.) The Trigger Input and the Pad Input Jack are provided for using the RSD-10 as an external sound source of a rhythm machine, and for producing the sound with dynamics that can vary by hitting the pad. The Playback Trim and Overdub Level controls can be effectively used for changing the length of the playback sound and for overdubbing.

* To use the RSD-10 as a sampler, you need the Pedal Switch DP-2, the Pad BP-1, rhythm machine (with Trigger Out) or a keyboard (synthesizer).

CONTENTS

| | |
|---|----|
| 1 Panel Descriptions | 4 |
| 2 Setup Examples and Operation | 6 |
| 1. Sampler Mode | 6 |
| a. Control with a Pedal Switch | 6 |
| b. Control with a Rhythm Machine | 9 |
| c. Control with a Pad | 12 |
| d. Control with a Keyboard | 15 |
| 2. Delay Mode | 19 |
| a. Standard Delay Effect | 20 |
| b. Special Delay Effect | 20 |
| 3 How to use a Cassette Deck in the Sampler Mode | 21 |
| 1. As an External Memory Device | 22 |
| 2. As a Sequencer | 23 |
| 4 Summary of the Functions | 24 |
| 5 Important Notes | 26 |
| 6 Specifications | 27 |

1 PANEL DESCRIPTIONS

«Front Panel»

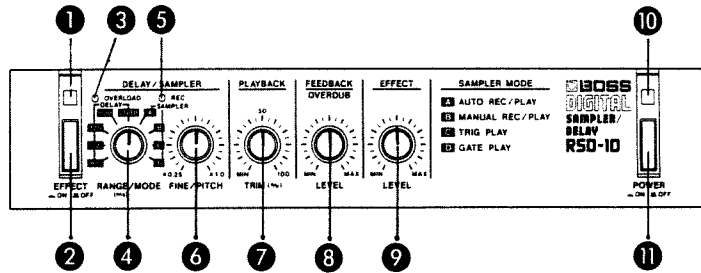

1 Effect Indicator

This lights up when the effect is turned on.

2 Effect Switch

Each time this switch is pushed, the effect is alternately turned on and off.

3 Overload Indicator

This lights up to tell you that excessive signal is fed in.

4 Delay Time Range/Sampler Mode Switch

This switch selects one of the 5 delay time ranges (8 to 2,000ms) or one of the 4 sampler modes.

5 Recording Indicator

When the RSD-10 is used as a sampler, this indicator lights up in the Auto-recording stand-by mode and flashes during recording.

6 Delay Time Fine/Sampler Pitch

When the RSD-10 is used as a delay machine, this knob works as a fine adjust control for the delay time. The set delay time range changes continuously "× 0.25" to "× 1.0," that is, using the Delay Time Range Switch and this Fine Knob, the delay time of 2 to 2,000ms can be continuously set.

When the RSD-10 is used as a sampler, this knob sets the sampling time and adjusts the pitch of the playback sound. 500 to 2,000 ms can be continuously set and the pitch of the playback sound alters as well. Rotating the knob clockwise lowers the pitch and rotating it counterclockwise raises the pitch.

7 Playback Trim

When the RSD-10 is used as a sampler, this knob determines the length of the playback sound, from MIN to 100% continuously, cutting unnecessary sound. This knob works only in the Sampler mode.

8 Feedback Level/Overdub Level

When the RSD-10 is used as a delay machine, this knob selects how many times the delay should be repeated. Rotating the knob clockwise increases the repetition number, and at the MIN position, single delay is obtained.

When the RSD-10 is used as a sampler, this knob adjusts the level of the overdubbing. As you rotate the knob clockwise, the previous sample sound is mixed with the new one therefore overdubbing effect is obtained. For sampling a new sound, set the knob to the MIN position.

9 Effect Level

This adjusts the level of the effect (delay/sampling) sound. Rotating the knob clockwise increases the level. At the MAX position, the direct and the effect sounds are almost equal, and at MIN, only the direct sound is obtained.

10 Power Indicator

11 Power Switch

The RSD-10 starts working after about 10 seconds.

◀Rear Panel▶

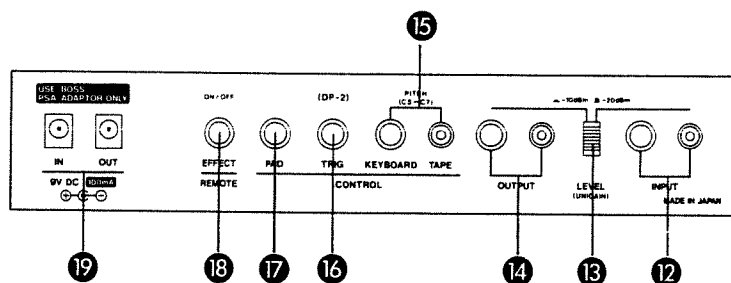

12 Input Jacks

Connect a musical instrument or audio equipment to these jacks.

* The standard phone jack and pin jack do not work at the same time. If both are simultaneously connected, the standard phone jack has priority.

13 Level Switch

Change the position of this switch depending on the output level of the connected device. If the Overload Indicator frequently lights up with this switch set to the “-20dBm” position, change it to “-10dBm”.

14 Output Jacks

When the effect is turned off, these jacks send out the mixed signal of the direct sound and the signal of the keyboard and the tape recorder connected to the Control Jacks 15. When the effect is turned on, the same jack sends out the mixed sound of the direct and delay/sample.

* The standard phone and the pin jacks can work simultaneously.

15 Pitch Control Jacks

These jacks are for feeding the audio signal that controls the pitch of the Sampler. The Tape Jack cannot

be used on its own; use it and the Keyboard Jack together. The Keyboard Jack can be used independently.

* As the pitch controlling audio signal, use a simple waveform (\sim , \wedge or \square): organ tone (envelope curve: $\text{—} \text{—} \text{—}$) of the sound range of C5 to C7. (See page 14.)

* When the Keyboard Jack is connected, the Delay Time Fine/Sampler Pitch Knob 6 on the front panel does not work.

16 Trigger Control Jack

Connect this jack to the pedal switch DP-2 (optional) or the Trigger Out of the rhythm machine.

17 Pad Control Jack

Connect this jack to the Pad Controller BP-1 (optional) or other drum pad.

* Depending on the drum pad used, the sensitivity may slightly differ.

18 Effect Remote Jack

This Jack is used for connecting the foot switch FS-1 (optional) to turn the effect on or off.

* When using this jack, be sure to turn the Effect Switch on the front panel on.

19 AC Adaptor Jacks

Usually, connect the AC adaptor (BOSS PSA Series: optional) to “IN”. However, for supplying power to other BOSS Micro Studio Series, connect the supplied DC cord to “OUT”.

* When using only an AC adaptor for supplying power to more than one unit, please be sure that the total current draw does not exceed 200mA. The RSD-10's current draw is 100mA. (The current draw of each unit is shown on its rear panel.)

2 SETUP EXAMPLES AND OPERATION

1 Sampler Mode

a. Control with the Pedal Switch

CONNECTIONS

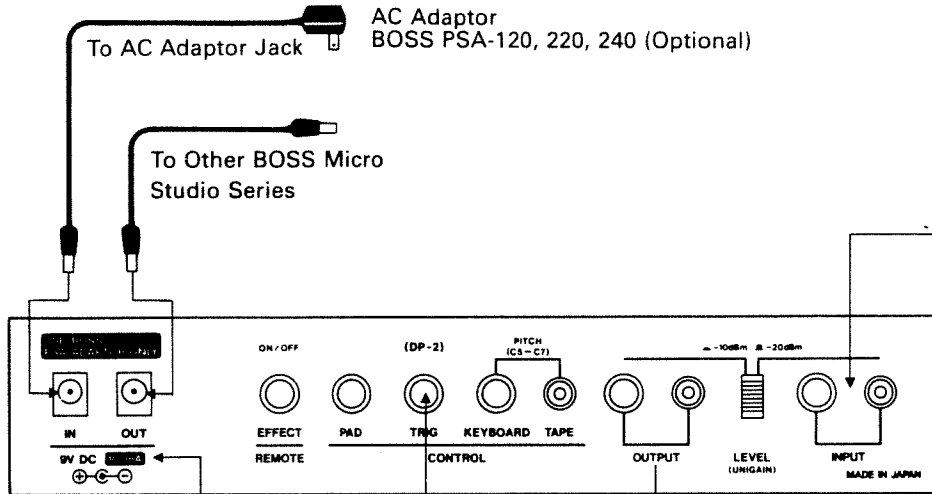

All the BOSS Micro Studio Series show the current draw here.

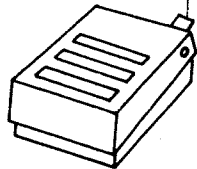

Pedal Switch (DP-2: Optional)

AC Adaptor
BOSS PSA-120, 220, 240 (Optional)

To AC Adaptor Jack

To Other BOSS Micro Studio Series

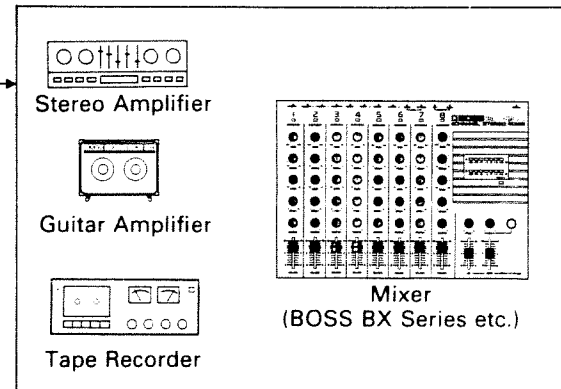
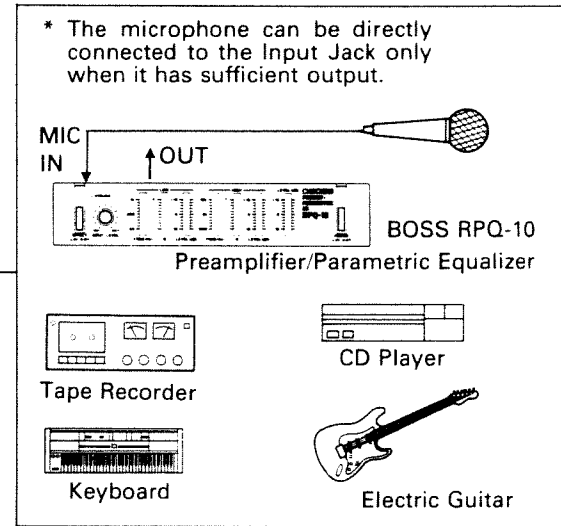

■ OPERATION

«Preparation»

- ① Make all the necessary connections and set the Level Switch ⑬ to the appropriate position depending on the device you use.



LEVEL
(UNIGAIN)

- * Usually select the “-20dBm” position, but change to the “-10dBm” if the Overload Indicator lights frequently.

- ② Set each knob as shown below.

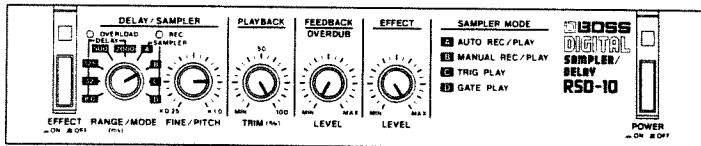

«Recording»

- * There are two methods for recording: **Manual** and **Auto**.

I. Manual Recording

- ③ Depress the Pedal Switch in the timing of the sound to be recorded.

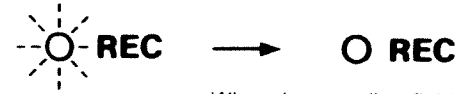

Flashes during recording

When the recording finishes, this goes out, and the RSD-10 is turned to the Playback mode.

The moment the pedal is pressed, recording will start (playback starts at the same time) and the Recording Indicator ⑤ flashes. When the sampling time set with the Pitch Knob ⑥ has elapsed, the recording automatically stops.

II. Auto Recording

- ③ Set the Sampler Mode Switch ④ to the **A** position

The Recording Indicator lights up showing it is now in the Auto-recording Stand-by mode.

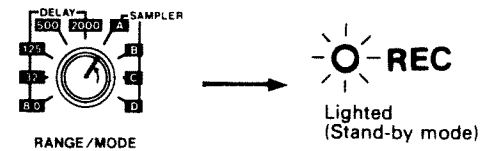

- * When any signal is being fed into the RSD-10, the above operation does not turn it to the stand-by mode.

④ **Feed the sound to be sampled.**

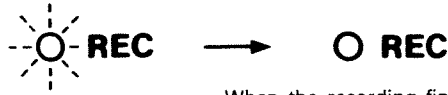

Flashes during recording

When the recording finishes, this goes out, and the RSD-10 is turned to the Playback mode.

The moment the sound is fed, recording will start (playback starts at the same time) and the Recording Indicator ⑤ flashes. When the sampling time set with the Pitch Knob ⑥ has elapsed, the recording automatically stops and the RSD-10 is changed to the playback mode.

- * To ensure the above operation, the sensitivity may be set rather high. Therefore, the recording may unexpectedly start by irrelevant element such as noise. Also, to record from the middle of the music, do it in the Manual recording mode.
- * The head of the sound may be missed out if it is extremely quick attack sound.
- * To rerecord the sound, set the Sampler Mode Switch ④ to the B position then return to A.

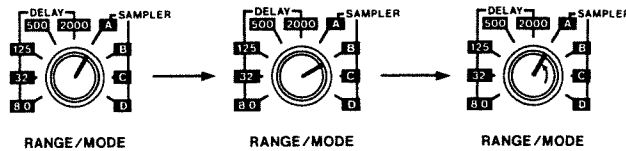

⑤ **For overdubbing, rotate the Overdub Level Knob ⑧ clockwise, then repeat the steps ③ (or ④).**



«Playback»

⑥ **Set the Sampler Mode Switch ④ to the C position, then depress the pedal switch.**

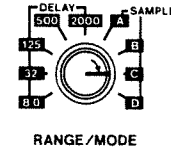

Each time you press the pedal, the sampled sound will be played back.

- * When the Sampler Mode Switch is set to the D (Gate Play Mode) position, playback is not possible.

⑦ **To change the pitch of the sound, use the Pitch Knob ⑥, and to change the length of the sound, use the Playback Trim Knob ⑦.**

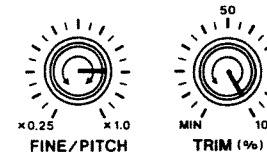

When the Playback Trim Knob ⑦ is set to the "100%" position, the recorded sound is fully played back. As the knob is rotated counterclockwise, the later parts of the sound are cut.

- * As the pitch of sound is altered, the timbre changes slightly, but this is not the mechanical trouble at all.

b. Control with the Rhythm Machine

■ CONNECTIONS

AC Adaptor
BOSS PSA-120, 220, 240 (Optional)

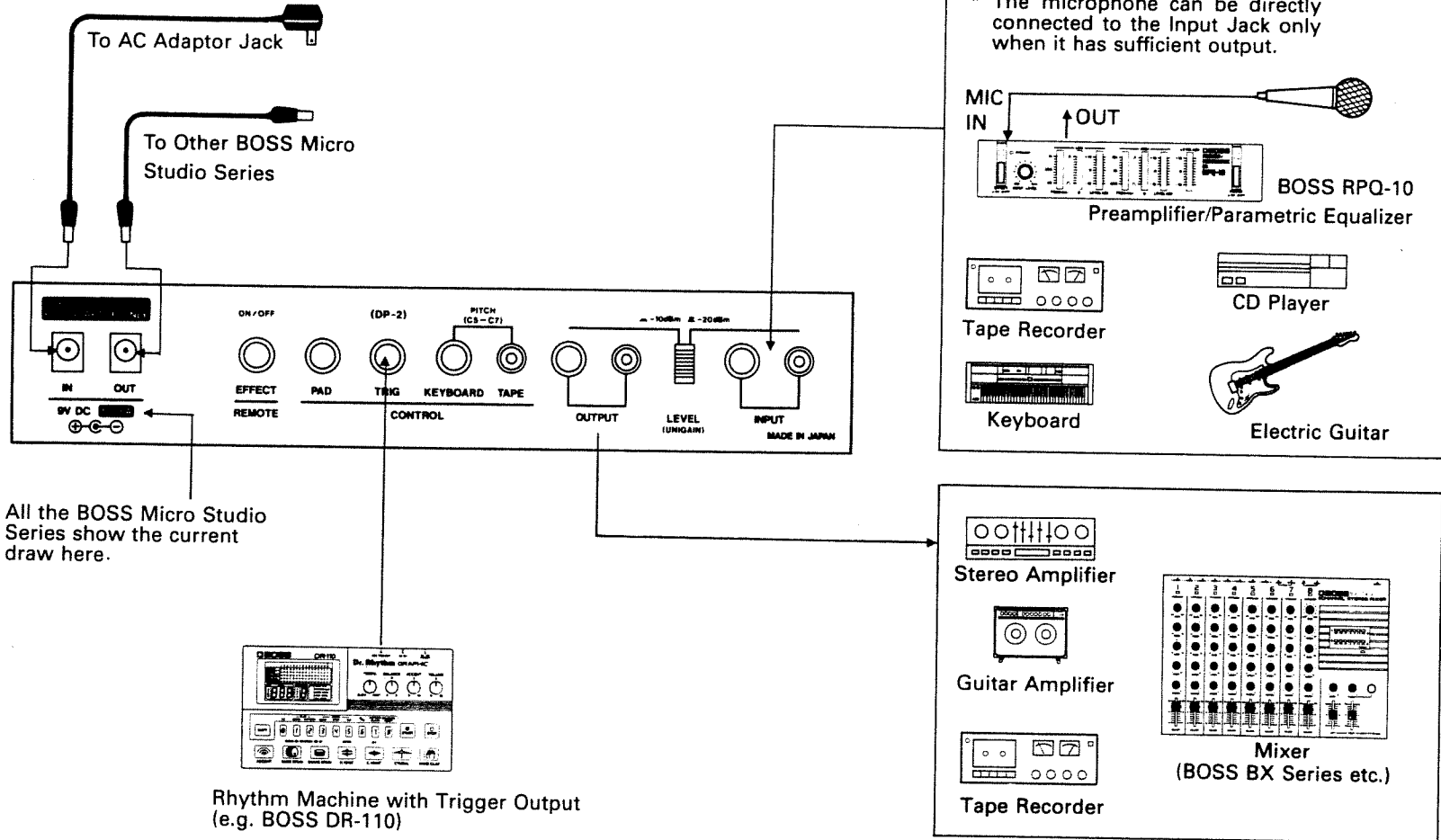

■ OPERATION

«Preparation»

- ① Make all the necessary connections and set the Level Switch ③ to the appropriate position depending on the device you use.



LEVEL
(UNIGAIN)

- * Usually select the “-20dBm” position, but change to the “-10dBm” if the Overload Indicator lights frequently.

- ② Set each knob as shown below.

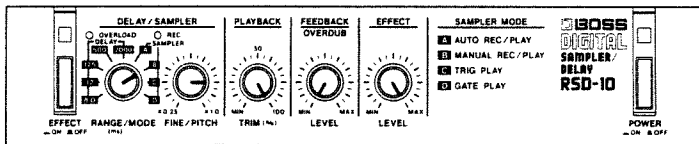

«Recording»

- * There are two methods for recording: **Manual** and **Auto**.

I. Manual Recording

- ③ Feed trigger signal in the timing of the sound to be recorded.

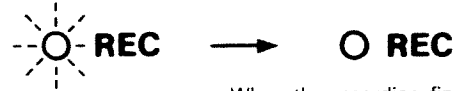

Flashes during recording

When the recording finishes, this goes out, and the RSD-10 is turned to the Playback mode.

The moment the signal is fed, recording will start (playback starts at the same time) and the Recording Indicator ⑤ flashes. When the sampling time set with the Pitch Knob ⑥ has elapsed, the recording automatically stops.

- * When the rhythm machine cannot send trigger signal in the above Manual Recording method, try the following Auto-recording method or use the pedal switch (see page 6).

II. Auto Recording

- ③ Set the Sampler Mode Switch ④ to the **A** position.

The Recording Indicator lights up showing it is now in the Auto-recording stand-by mode.

* When any signal is being fed into the RSD-10, the above operation does not turn it to the stand-by mode.

④ **Feed the sound to be sampled.**

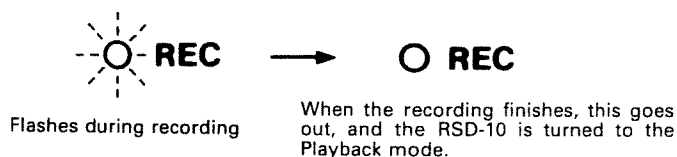

The moment the sound is fed, recording will start (playback starts at the same time) and the Recording Indicator ⑤ flashes. When the sampling time set with the Pitch Knob ⑥ has elapsed, the recording automatically stops and the RSD-10 is changed to the playback mode.

* To ensure the above operation, the sensitivity may be set rather high. Therefore, the recording may unexpectedly start by irrelevant element such as noise. Also, to record from the middle of the music, do it in the Manual recording mode.

* The head of the sound may be missed out if it is extremely quick attack sound.

* To rerecord the sound, set the Sampler Mode Switch ④ to the B position then return to A.

⑤ **For overdubbing, rotate the Overdub Level Knob ⑧ clockwise, then repeat the steps ③ (or ④).**

◀**Playback**▶

⑥ **Set the Sampler Mode Switch ④ to the C position, then start the rhythm machine.**

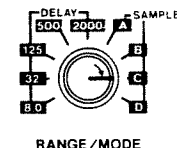

Each time the trigger signal is fed into the RSD-10, the sampled sound will be played back.

* When the Sampler Mode Switch is set to the D (Gate Play Mode) position, playback is not possible.

⑦ **To change the pitch of the sound, use the Pitch Knob ⑥, and to change the length of the sound, use the Playback Trim Knob ⑦.**

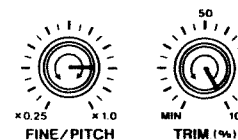

When the Playback Trim Knob ⑦ is set to the "100%" position, the recorded sound is fully played back. As the knob is rotated counterclockwise, the later parts of the sound are cut.

* As the pitch of sound is altered, the timbre changes slightly, but this is not the mechanical trouble at all.

c. Control with a Pad

■ CONNECTIONS

AC Adaptor
BOSS PSA-120, 220, 240 (Optional)

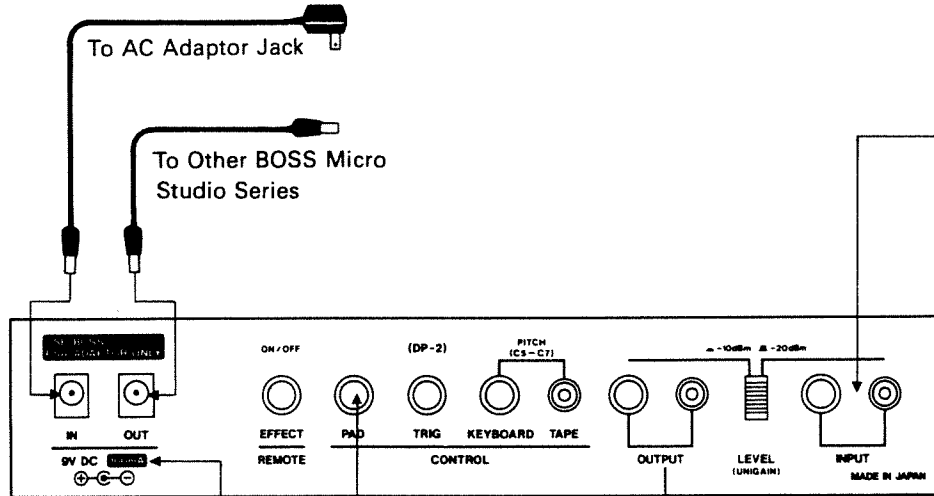

All the BOSS Micro Studio Series show the current draw here.

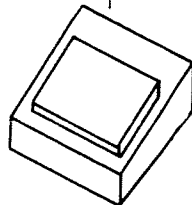

External Pad (BP-1: Optional)

* When the Pad Jack is plugged in, the Trig Jack does not work.

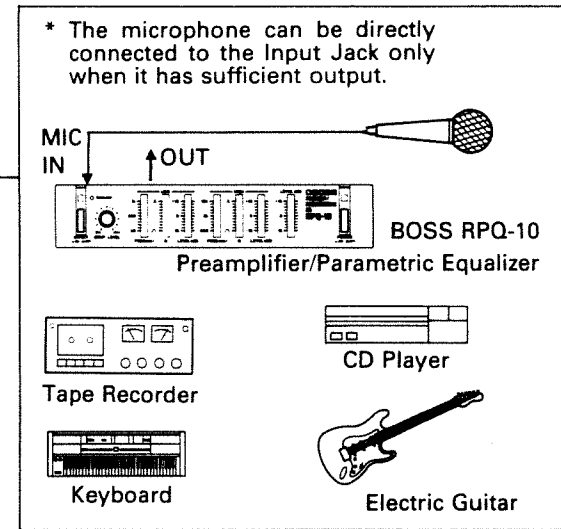

* The microphone can be directly connected to the Input Jack only when it has sufficient output.

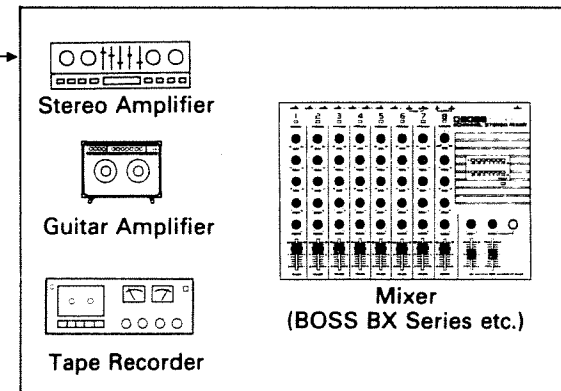
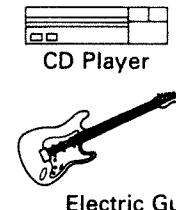
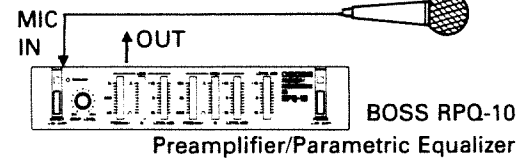

■ OPERATION

«Preparation»

- ① Make all the necessary connections and set the Level Switch to the appropriate position depending on the device you use.



LEVEL
(UNIGAIN)

- * Usually select the “-20dBm” position, but change to the “-10dBm” if the Overload Indicator lights frequently.

- ② Set each knob as shown below.

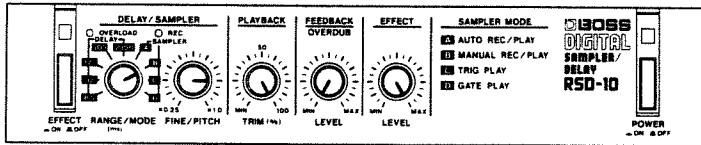

«Recording»

- * There are two methods for recording: **Manual** and **Auto**.

I. Manual Recording

- ③ Hit the pad in the timing of the sound to be recorded.



Flashes during recording

When the recording finishes, this goes out, and the RSD-10 is turned to the Playback mode.

The moment the pedal is pressed, recording will start (playback starts at the same time) and the Recording Indicator ⑤ flashes. When the sampling time set with the Pitch Knob ⑥ has elapsed, the recording automatically stops.

II. Auto Recording

- ③ Set the Sampler Mode Switch ④ to the **A** position.

The Recording Indicator lights up showing it is now in the Auto-recording stand-by mode.

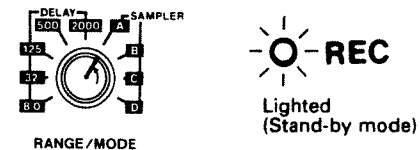

- * When any signal is being fed into the RSD-10, the above operation does not turn it to the stand-by mode.

④ **Feed the sound to be sampled.**

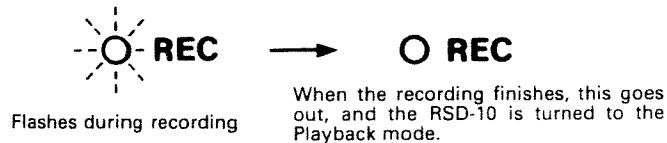

The moment the sound is fed, recording will start (playback starts at the same time) and the Recording Indicator ⑤ flashes. When the sampling time set with the Pitch Knob ⑥ has elapsed, the recording automatically stops.

- * To ensure the above operation, the sensitivity may be set rather high. Therefore, the recording may unexpectedly start by irrelevant element such as noise. Also, to record from the middle of the music, do it in the Manual recording mode.
- * The head of the sound may be missed out if it is extremely quick attack sound.
- * To rerecord the sound, set the Sampler Mode Switch ④ to the B position then return to A.

I Manual Recording

⑤ **For overdubbing, rotate the Overdub Level Knob ⑧ clockwise, then repeat the step ③.**

- * Depending on how hard you hit the pad, the dubbing level changes.

II Auto Recording

⑤ **For overdubbing, disconnect the plug from the Pad Control Jack ⑭, rotate the Overdub Level Knob ⑧ clockwise and repeat the steps ③ and ④.**

- * Overdubbing is not possible when the plug is connected to the Pad Control Jack.

Playback

⑥ **Set the Sampler Mode Switch ④ to the C position, then hit the pad.**

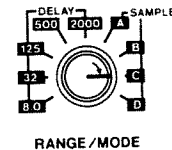

Each time you hit the pad, the sampled sound with dynamics will be played back.

- * Depending on the pad used, sensitivity may slightly differ.

⑦ **To change the pitch of the sound, use the Pitch Knob ⑥, and to change the length of the sound, use the Playback Trim Knob ⑦.**

When the Playback Trim Knob ⑦ is set to the "100%" position, the recorded sound is fully played back. As the knob is rotated counterclockwise, the later parts of the sound are cut.

- * As the pitch of sound is altered, the timbre changes slightly, but this is not the mechanical trouble at all.

d. Control with the Keyboard

■ CONNECTIONS

AC Adaptor
BOSS PSA-120, 220, 240 (Optional)

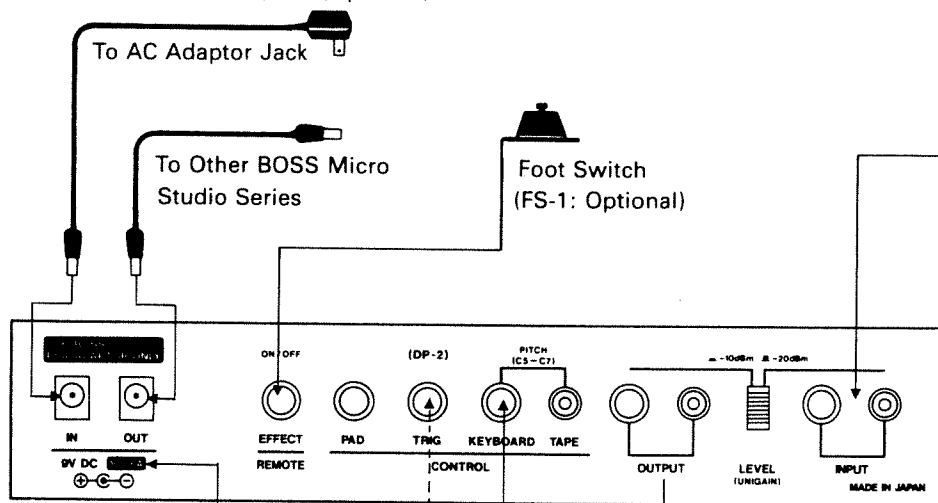

All the BOSS Micro Studio Series show the current draw here.

* If the synthesizer features the Gate Output, use it as well as the Audio Output. In this way, the RSD-10 operates more stably. Here, slightly raise the release time of the ENV generator.

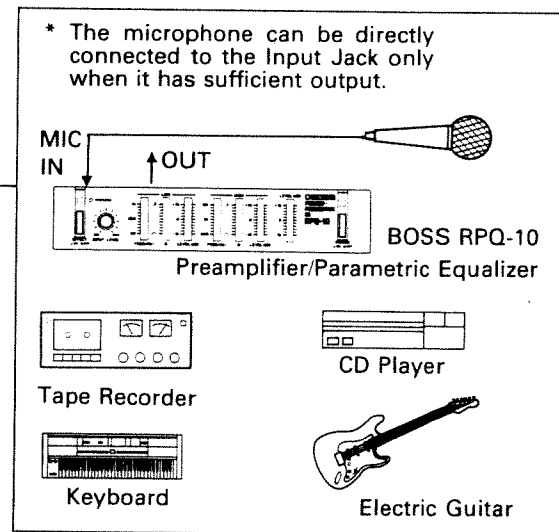
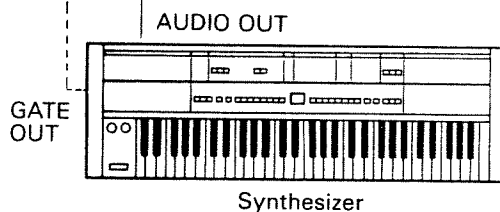

* The microphone can be directly connected to the Input Jack only when it has sufficient output.

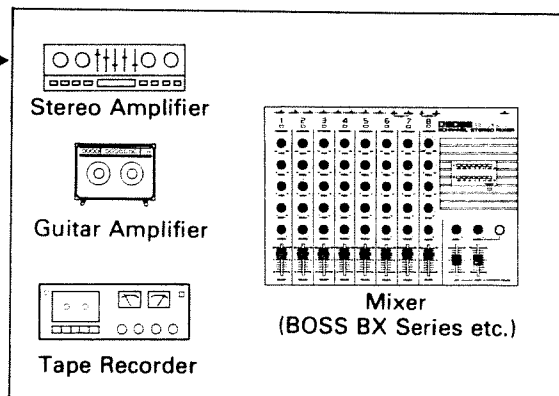

* About the Pitch Controlling Keyboard

The RSD-10 features the newly developed pitch controlling circuit that works with audio signal. This circuit detects the pitch of the audio signal and uses it for controlling the operation speed of the recording/playback. (The pitch alters by changing the playback speed.) Any synthesizer can be used as a pitch controlling keyboard, if it produces the organ tone (= envelope: $\square \square$) in the range of C5 (523.3Hz) to C7 (2093Hz). The sampling time is 2,000ms for the audio signal of C5, and 500ms for C7. If recorded with the load point of C6, the sound will be played back in the same pitch at C6, and one octave lower at C5 and one octave higher at C7. (The load point can be set to any pitch you like.) See page 25

- * When using a polyphonic synthesizer, please be sure that not more than one key is played at a time. If possible, set it to the MONO Mode.
- * If you play a chord, sound with chorus effect or any complicated waveform, it will not be played back.
- * If the audio signal lower than C5 is fed into the RSD-10, beat may be caused.
- * Using an electric guitar instead of a keyboard will cause a great deal of trouble.

«Preparation»

- ① **Make all the necessary connections and set the Level Switch to the appropriate position depending on the device you use.**



LEVEL
(UNIGAIN)

- * Usually select the “-20dBm” position, but change to the “-10dBm” if the Overload Indicator lights frequently.

- ② **Set each knob as shown below.**

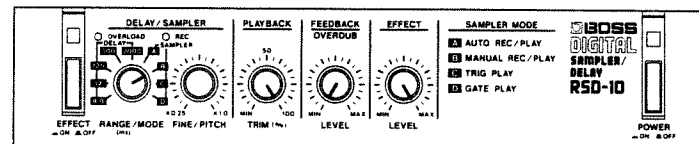

«Recording»

- ③ To set the load point, play the key you wish to sample within the range of C5 to C7 for about a second.

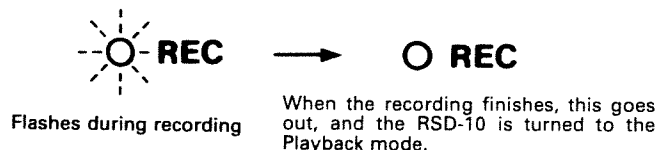

The Recording Indicator ⑤ flashes showing that the sampling load point is set. Now, recording (playback as well during overdubbing) can be done, so, play the key to the sound to be recorded. (Manual Recording)

- ④ Set the Sampler Mode Switch ④ to the **A** position.

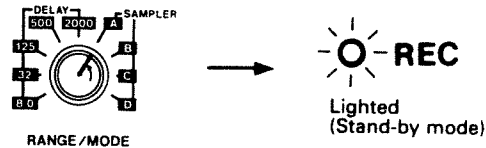

The Recording Indicator lights up showing it is now in the Auto-recording stand-by mode.

- * When any signal is being fed into the RSD-10, the above operation does not turn it to the stand-by mode.

- ⑤ Feed the sound to be sampled.

The moment the sound is fed, recording will start (playback starts as well) and the Recording Indicator ⑤ flashes. When the sampling time set with the Pitch Knob ⑥ has elapsed, the recording automatically stops and the RSD-10 is changed to the playback mode.

- * To ensure the above operation, the sensitivity may be set rather high. Therefore, the recording may unexpectedly start by irrelevant element such as noise. Also, to record from the middle of the music, do it in the Manual recording mode.
- * The head of the sound may be missed out if it is extremely quick attack sound.
- * To rerecord the sound, set the Sampler Mode Switch ④ to the **B** position then return to **A**.

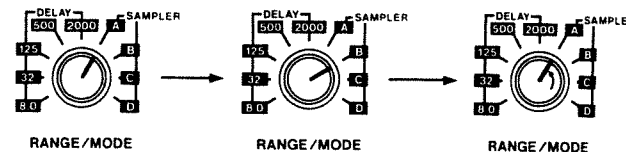

- ⑤ For overdubbing, rotate the Overdub Level Knob ⑧ clockwise, then repeat the step ③, ④ and ⑤.



Playback

- ⑦ Set the Sampler Mode Switch ④ to the **C** or **D** position, then play the keyboard.

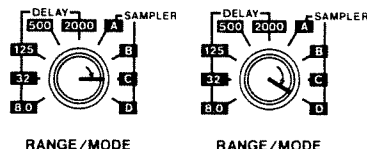

The sampled sound will be played back according to the key played.

- ⑧ To make the keyboard's output level in the **D** mode equal to that in the **C** mode, try changing the Sampler Mode Switch ④ alternately to the **C** and **D** positions and playing the keyboard.

The volume in the **C** mode does not change, but that in **D** mode is adjustable. When using the keyboard with dynamics, play the keyboard rather hard for adjusting the level. **In the C mode**, the sampled sound will be all played back no matter how short you touch the keyboard.

- * When the RSD-10 is set to the position **A**, **B** or **C**, it detects the pitch of the sound's head for about 50ms. Therefore, the staccato (shorter than 50ms) or unstable sound is not suitable for pitch controlling; wrong pitch is recorded or played back. Playback with dynamics is not possible.

In the D mode, the sampled sound can be played back only while the key is played.

To obtain the effect such as dynamics, pitch bender, vibrato, portamento etc, set the RSD-10 to the **D** mode. (These effect does not work in any other mode.)

- * Changing the pitch will slightly alter the timbre simultaneously.

- ⑨ Using the Playback Trim Knob, adjust the length of the playback sound.



At 100%, the recorded sound will entirely played back. As you rotate the knob counterclockwise, the tail of the sound will be cut.

- ⑩ If you wish to play with the original sound of the synthesizer, turn the Effect Switch ② off.

The Effect Indicator ① goes out, and the keyboard signal will be bypassed.

2 Delay Mode

■ CONNECTIONS

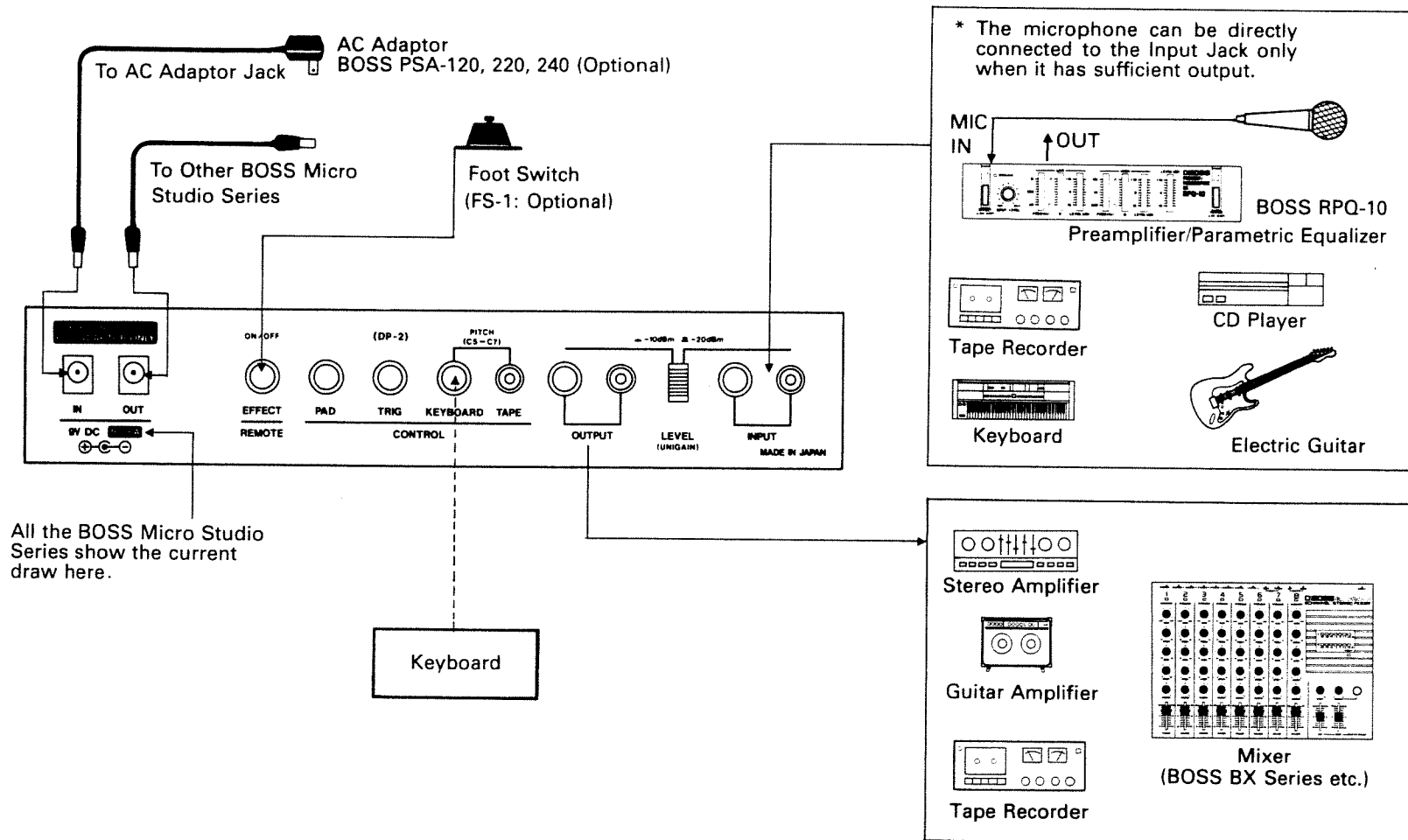

a. Standard Delay Effect

■ OPERATION

- ① Make all the necessary connections, and set the knobs on the panel as shown below.

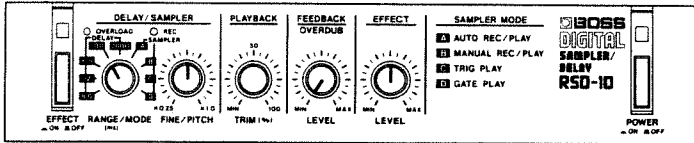

- ② Set the Level Switch to the appropriate position depending on the device you use.

* Usually select the “-20dBm” position, but change to the “-10dBm” if the Overload Indicator lights frequently.

- ③ Set the delay time you like by using the Delay Time Range Switch ④ and the Delay Time Fine Knob.

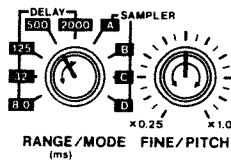

- ④ Set the repetition number of the delay sounds by using the Feedback Level Knob ⑧.



- * At MIN position, single delay is obtained.
- * As you rotate the knob clockwise, oscillation may occur.

- ⑤ Adjust the volume of the delay sound with the Effect Level Knob ⑨.



- * At MAX position, the volume of the delay and the direct sounds are equal.

b. Special Delay Effect (“Semi-tone Flanging” Effect)

The delay time can be controlled by the keyboard. Set the Delay Time Range Switch ④ to “8ms”, and play the keyboard within the range of C5 to C7, then the center frequency of the flanging effect can be controlled in semi-tone steps.

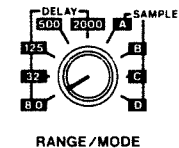

- * Regarding the tone color and sound range of the keyboard, see page 16 & 25.

3 How to use the Cassette Deck in the Sampler Mode

■ CONNECTIONS

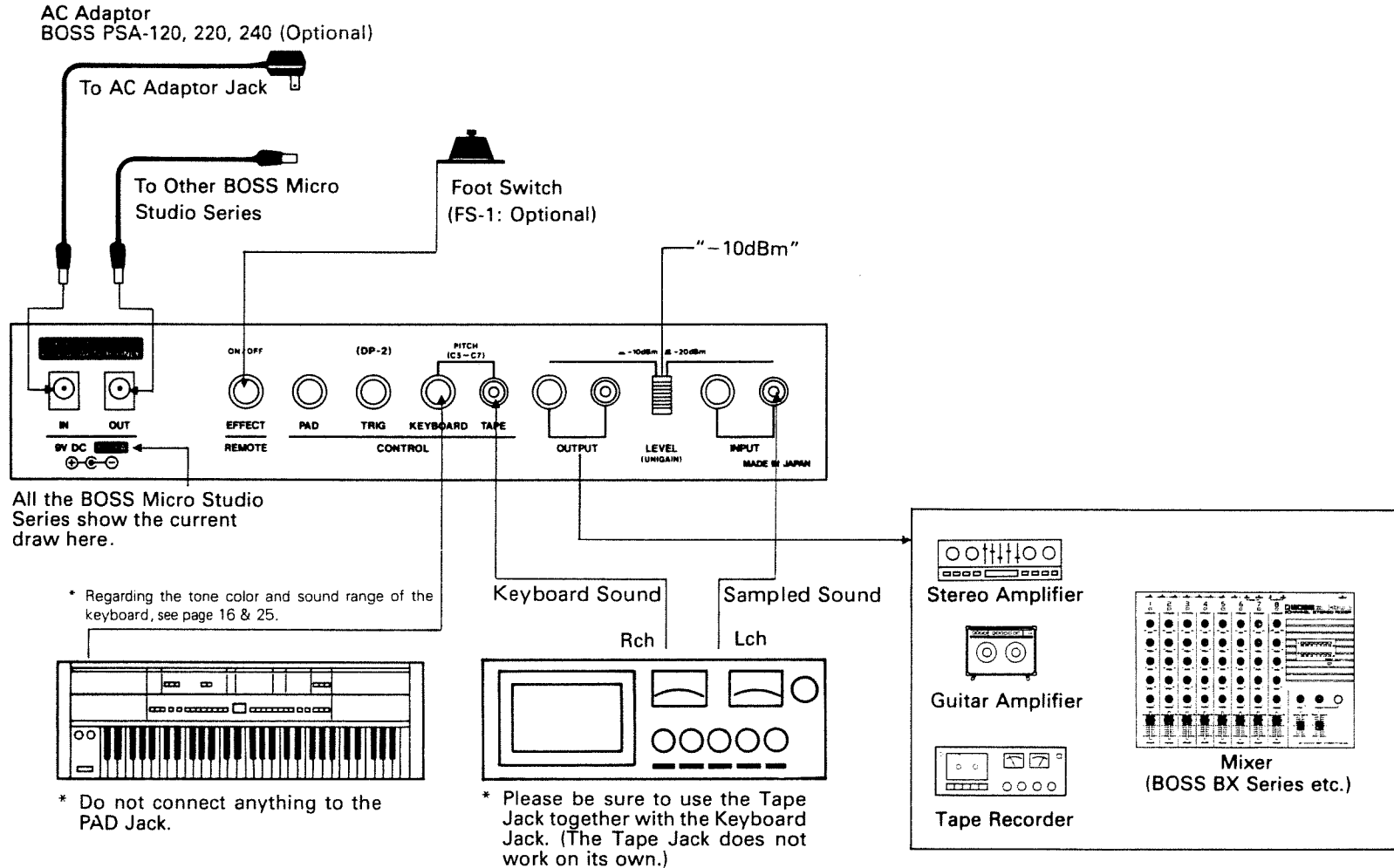

1 As an External Memory Device for the Tone Data

The data in the RSD-10 will be erased when it is switched off. To retain the data and use it later, take the following operation.

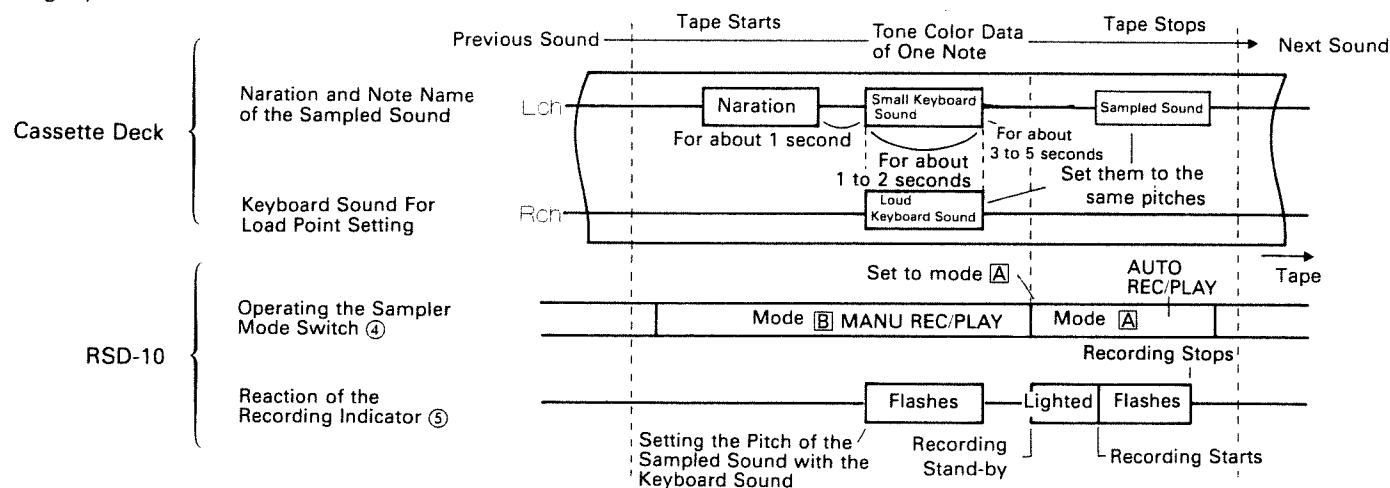

OPERATION

- Record the naration (e.g. note name of sampled sound) and the sampled sound (the sound to be saved and loaded back later) on the L channel. On the R channel, record the keyboard sound (for load point setting). Now, the load point can be automatically set.

* The pitch of the keyboard should be the same as the note name of the sampled sound. Otherwise, the loading will not be done in a correct pitch.

- Set up the cassette deck and the keyboard as shown in "■ Connection" on page 20 and set the knobs on the panel as shown below.

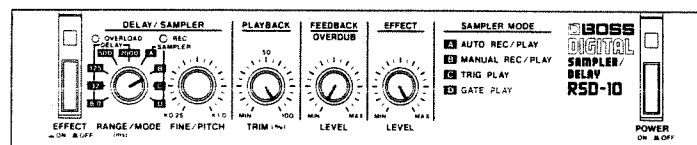

③ Start the cassette deck.



The Recording Indicator ⑤ lights up and the load point is set to the pitch of the keyboard sound on the R channel.

④ Make sure that the Recording indicator goes out and quickly change the position of the Sampler Mode Switch ④ to A.

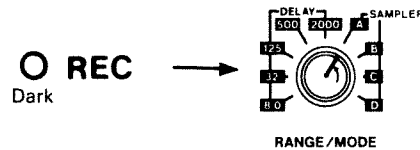

The Recording Indicator lights up and the moment the sampled sound (to be loaded) is fed in, the same indicator flashes and loading starts.

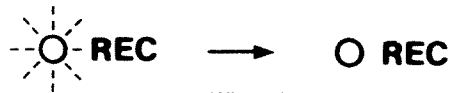
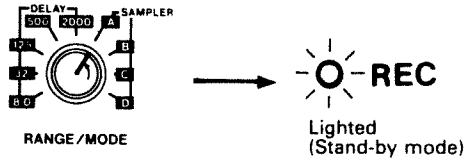

Flashes during recording

When the recording finishes, this goes out, and the RSD-10 is turned to the Playback mode.

⑤ Make sure that the Recording Indicator ⑤ goes out then stop the cassette deck.

* During the above procedures ③ to ⑤, do not play the keyboard.

⑥ Set the Sampler Mode Switch ④ to the C or D position and play the keyboard.

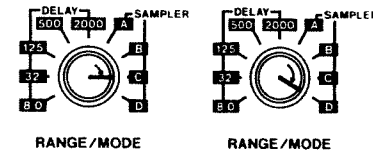

* If you do not need the previous playback sound, take the loading operation with the Effect Switch turned off or the Effect Level Knob fully turned down.

2. As a Sequencer

By recording the keyboard sound onto the cassette deck and feeding the playback sound to the RSD-10 through the Pitch Control Tape Input Jack, the sampled sound will be automatically played back.

4 Summary of the Functions (Delay Range/Sampler Mode Switch 4)

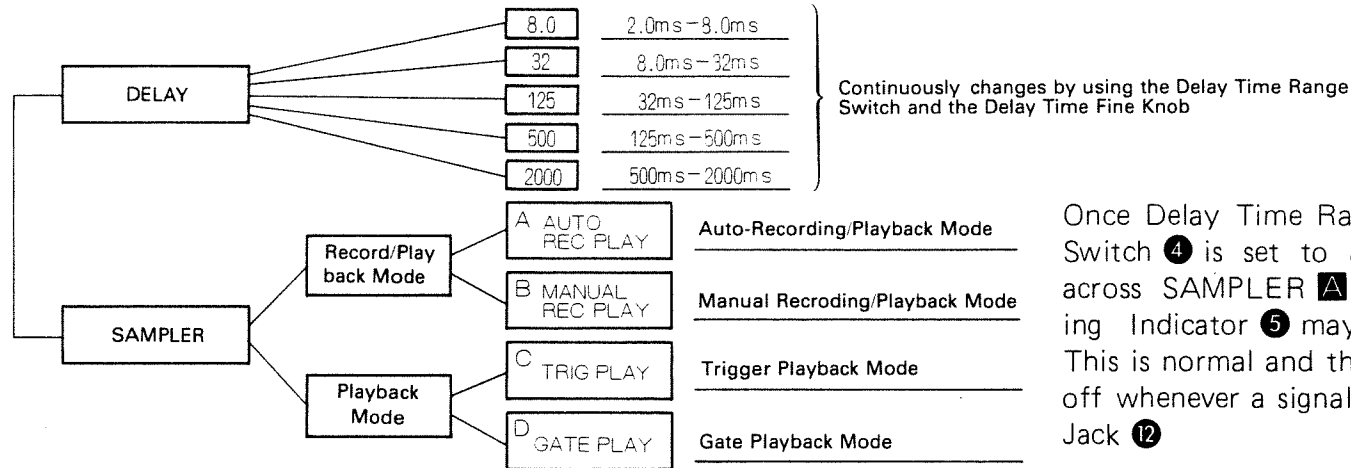

Once Delay Time Range/Sampler Mode Switch 4 is set to a position (mode) across SAMPLER A position, Recording Indicator 5 may remain lighted. This is normal and the indicator will go off whenever a signal is fed from Input Jack 12

A ... Auto-recording/Playback Mode

When the switch is changed from B to A, the Recording Indicator 5 lights up, showing that RSD-10 is now auto-recording stand-by mode. When the audio signal is fed, the indicator flashes and the recording (and simultaneously the playback of the recorded sound) starts. When the recording finishes, the indicator goes out and the RSD-10 is turned to the Trigger Playback mode.

B ... Manual Recording/Playback Mode

In this mode, the recording (and simultaneously the playback of the recorded sound) starts each time the trigger is fed into. Trigger can be sent with the foot pedal switch, external trigger signal, pad or keyboard.

C ... Trigger Playback Mode

This mode can be used when the sampled sound is being played back by the trigger signal (with the foot pedal switch, rhythm machine, pad etc.). When the keyboard is used, recorded sounds are entirely played back no matter how quickly the key is released.

D ... Gate Playback Mode

When the keyboard is being used, the sampled sound is played back only while the key is pressed. Also, in this mode, the dynamics, pitch bender, vibrato effect, etc. can be controlled if the keyboard used features these functions. (This is not possible in any other mode.)

■ Tone Color Setting Examples for Pitch Controlling Keyboard (Synthesizer)

● When using an analog synthesizer (JX-8P, PG-800)

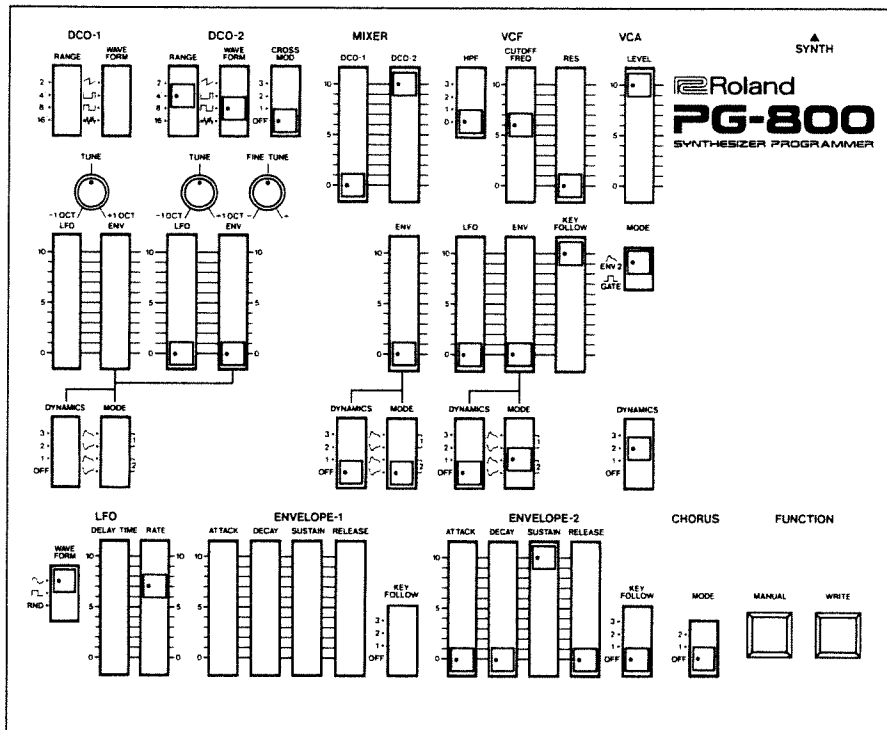

● When using Digital Synthesizer

Select 4 feet Range, ~ (Sine Wave) and make organ-like tone (Envelope: \square).

VCO(DCO) Range → 4 feet

VCO(DCO) Waveform →

~ (Sine Wave), ~ (Triangle) or \square (Square)
 * \square (Pulse Wave) is not suitable.

VCF Cutoff Frequency → Normally MAX

VCF Resonance → MIN

Envelope for VCA → A : Attack Time MIN
 D : Decay Time MIN
 S : Sustain Level MAX
 R : Release Time MIN

* Set other knobs to your taste.

* To create a sine wave, set the VCF cutoff frequency rather low and set the Keyboard Follower to the MAX position.

* Please be sure to turn the Chorus effect off.

* When the Sampler Mode Switch ④ is set to \square , the attack time and the decay time of the sampled sound can also be controlled.

5 IMPORTANT NOTES

- If the created sound is unclear, it is most likely because of the beat. The beat can be reduced by rotating the Delay Time Fine/Sampler Pitch Knob ⑥ slightly counterclockwise or using the higher range of the keyboard.
- The RSD-10 is designed not to work for 10 seconds after switched on.
- Be sure to use the BOSS AC Adaptor PSA-120, 220 or 240 depending on the line voltage system in your country.
- When you are using only one AC adaptor for supplying power to more than one unit, please be sure that the total current draw does not exceed 200mA.
- Avoid operating this unit in excessive heat or humidity or where it may be affected by dust.
- Please never remove the cabinet from the unit.
- When you use the Micro Studio Series without optional Rack Mount Adaptor "RAD-10", please attach the rubber feet as shown below.

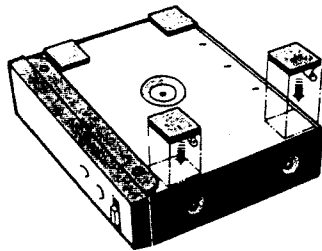

■ AC ADAPTOR

BOSS PSA-120, 220 or 240 (Optional)

Be sure to use the Adaptor BOSS PSA-Series. Using any other type of adaptor may cause trouble.

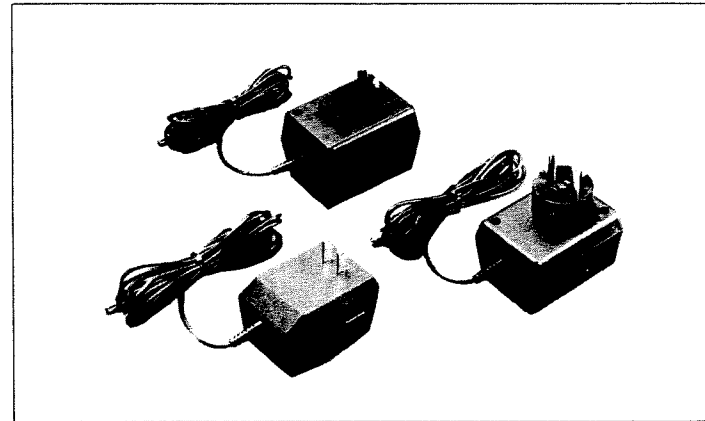

■ RACK MOUNTING

The RSD-10 is one of the BOSS Micro Studio Series, and any two of them can be mounted on a standard 19" rack (EIA-1U) by using the optional Rack Mount Adaptor RAD-10.

Remove the rubber feet from the bottom of the units, fix the units on the Rack Mount Adaptor with the supplied screws, then place the whole set on the rack.

6 SPECIFICATIONS

Input Level/Input Impedance:

–20dBm/1M Ω , –10dBm/47k Ω

Output Level/Output Impedance:

–20dBm/2k Ω , –10dBm/2k Ω

Output Load Impedance: More than 10k Ω

Type of A/D/A Converter: 12 bit + analog
logarithm compression

Sampling Time: Max. 2,000ms

Delay Time: 2 to 2,000ms

Frequency Response:

Direct: 10 Hz to 30 kHz (± 1 dB)

Sampler/Delay: 20Hz to 7kHz (± 1 dB) (Fine \times 0.25)

Residual Noise: –95dBm (IHF-A, Level Switch: –20dBm)

Input Range of the External Pitch Control:

C5 (523Hz) to C7 (2093Hz)

Controls: Delay Range/Sampler Mode

Delay Time Fine/Sampler Pitch

Playback Trim

Feedback/Overdub Level

Dealy/Sampler Level

Switches: Power

Effect (On/Off)

Level (–20dBm/–10dBm)

Jacks: Input (Standard phone, Pin)

Output (Standard phone, Pin)

Pitch Control Input (Standard phone, Pin)

Pad Control Input (BP-1)

Trigger Control Input (as well used for the DP-2)

Effect Remote (On/Off)

AC Adaptor (IN, OUT)

Indicators: Power

Effect

Overload

Recording

Power: 9V DC (BOSS PSA-120, 220, 240)

Durrent Draw: 100mA

Dimensions: 218 (W) \times 169 (D) \times 44 (H) mm
8 $\frac{9}{16}$ " \times 6 $\frac{11}{16}$ " \times 1 $\frac{3}{16}$ "

Weight: 1kg/2 lb 3oz

Accessory: DC Cord (0.5m)

Rubber Feet (\times 4)

Options: AC Adaptor BOSS PSA-120, 220 or 240

Pedal Switch DP-2

Foot Switch FS-1

Pad Controller BP-1

Rack Mount Adaptor RAD-10

(Micro System Rack BMR-5)

* Specifications are subject to change without notice.

BOSS Micro Studio Series

RCL-10

Compressor/Limiter

RBF-10

Flanger

RGE-10

Graphic Equalizer

RPQ-10

Preamplifier/

Parametric Equalizer

RPH-10

Phaser

RDD-10

Digital Delay

RSD-10

Digital Sampler/Delay

QUALITY PLAYBACK OF SAMPLINGS WITH A KEYBOARD

First read page14 for MODE Switch function and page25 for keyboard controller setting. The following is duplicated on pp.15-18.

Feed as simplest waveform as possible into KEYBOARD Jack of the RSD-10 with a single note at a time. Ideal Keyboard Setting For PLAYBACK in Sampler Mode.

WAVEFORM Sine, Triangular or Rectangular having less harmonics

KEY MODE Monopholic (one voice/note)

MODULATION All modulations that affect the shape of keyboard audio
must be OFF

AUDIO OUT LEVEL Set for:

- ※ Noise-free and distortion-free playback sound
- ※ Playback remains at the same level when MODE is changed from to and vice versa
- ※ With DYNAMICS keyboard an equal level is obtained only at maximum dynamics amount

 Roland®

10436

UPC 10436



1896

RSD-10



Products of Roland

RSD-10 Instructions Printed in Japan Sep. '86 C-3